

Powertrack 100

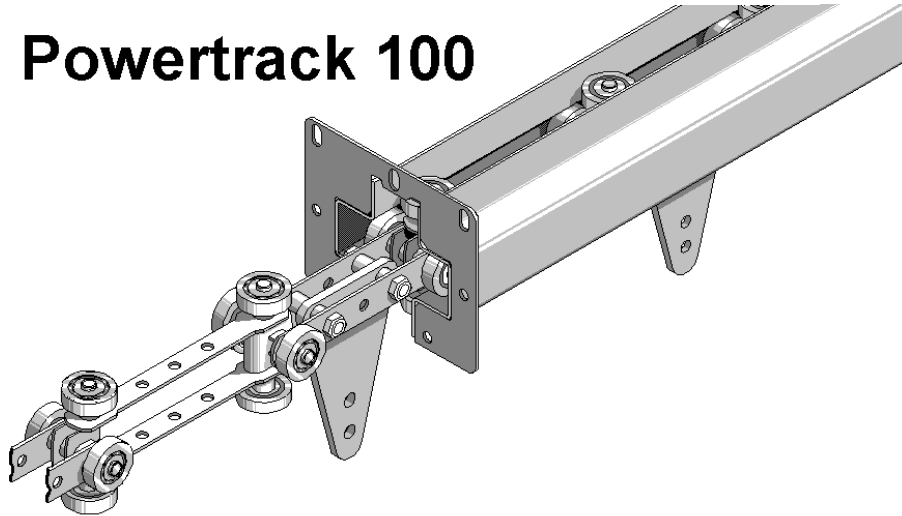

Suitable for a wide range of applications and processes, the **Powertrack 100** complements our extensive range of **Powertrack** conveyors.

Features

Designed for heavy duty applications providing a carrying capacity of up to 100kg per pendant with a 3mm wall twin 'top hat' track section for span loading.

Modular construction utilising many common components within the **Powertrack** range enabling easy installation and future alterations and extensions.

Suitable for operation through areas up to 250 deg. C makes it an ideal choice for all uses including transportation, process and paint finishing applications.

Compatible with a wide range of bearing types to suit applications.

As with the full Powertrack range, the modules are designed for easy installation at high level ensuring optimum free floor space for other operations.

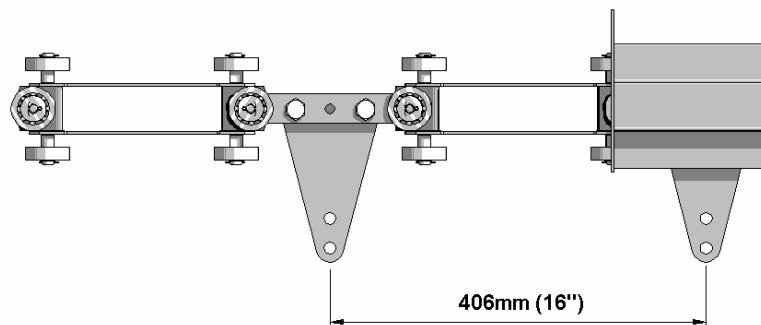

Powertrack 100 - technical specification

Drive

Comprising a caterpillar type drive renowned for smooth surge free power transmission. The unit would be driven by a helical worm drive geared motor unit incorporating a torque limiter shear unit for protection of the chain components.

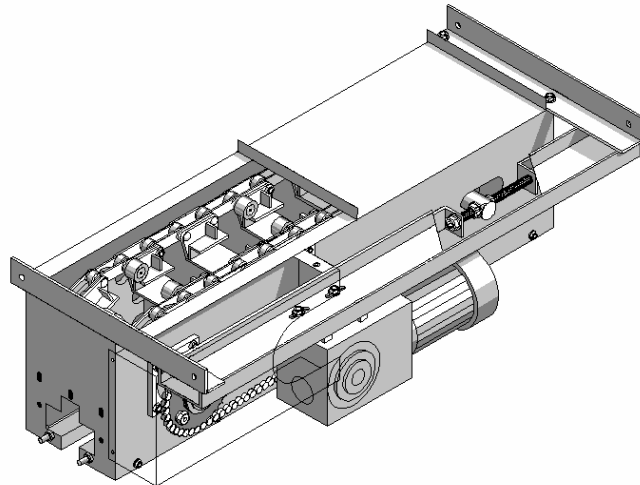

Chain

Heavy duty pendants can be fitted at increments of 406mm pitch, the sturdy fully bi-planer chain includes articulating joints with tensile steel side plates. Double 48mm

diameter wheels are incorporated vertically and horizontally and are fitted with steel cage ball bearings for optimum efficiency and trackability.

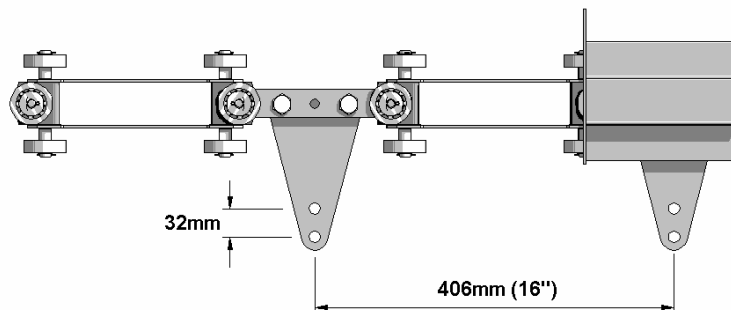

Track Section

Rolled from high quality steel to form a twin 'top hat' section with 3mm wall thickness with a 50mm slot in the vertical plane. The flange plates are nominally fitted at 600mm pitch and facilitates easy installation.

Powertrack 100

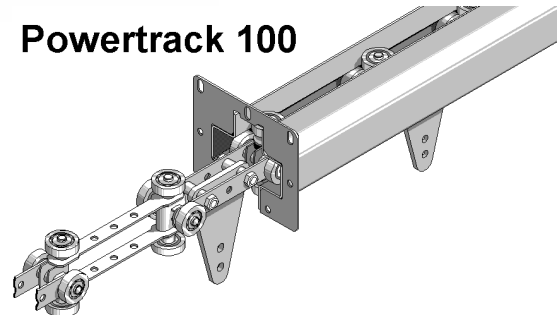

Powertrack 100 - technical specification cont.

Bend Sections

Bends have a standard radius of 762mm (horizontal) and 1118mm (vertical) – although other radii can be manufactured on request. Bends are available in 15, 30, 45, 60 and 90 degree segments.

Inspection Section

This would be incorporated in a readily accessible position within the system for easy inspection and carrying out preventative maintenance.

Tension Unit

All chain circuits require the means to set and maintain the correct working tension. To facilitate this, the tension unit comprises a 180 degree bend available with differing track centres to suit the system mounted below a frame with manual adjustment. It is recommended that the unit is incorporated following the drive unit. For extra wide applications linear tension units are utilised.

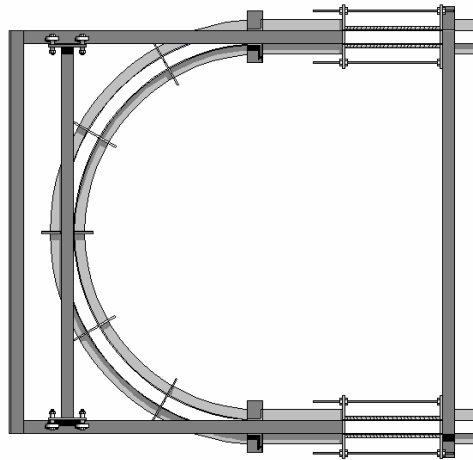

Lubricator

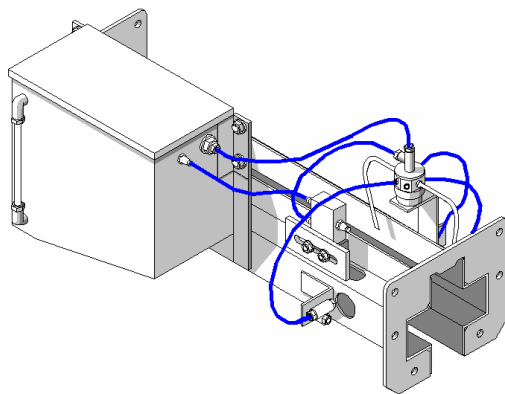

For long chain life, particularly when operating in high temperatures, lubrication is essential. The lubricator is a pneumatically powered unit which allows pulses of lubricant onto essential components. The unit includes a separate solenoid valve with silencer and regulator. Essential unit piping and connections would be pre-assembled and tested in our works.

Lubricator details

Requires compressed filtered air at 4 – 5 Bar.
Size of actuating valve inlet is 1/8" BSP/8mm dia tube.
Reservoir capacity – 3.5 litres.

Powertrack 100
Technical Data

Chainpull. Maximum allowable through the drive is 455kg.

Support data

<i>Support Pitch</i>	<i>Load per metre based upon uniform weight distribution</i>	<i>Max. point load central to support span (hung on 1 or 2 pendants)</i>
3500mm	138.5 kg / mtr	200.00 kg
3250mm	169.0 kg / mtr	200.00 kg
3000mm	210.0 kg / mtr	200.00 kg
2750mm	267.5 kg / mtr	200.00 kg
2500mm	N/A	N/A

* The above information is calculated from BS 5950: Part 1 : 1990 Section Two for horizontal deflection, based upon the Span / 500.

Module data

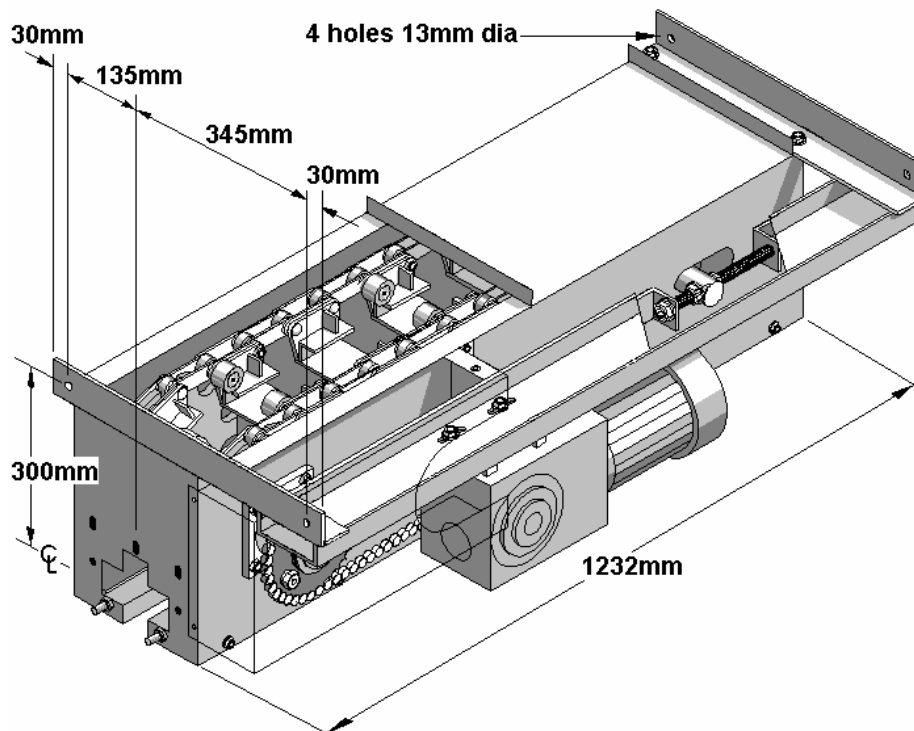

Drive Unit

Powertrack 100
Technical Data

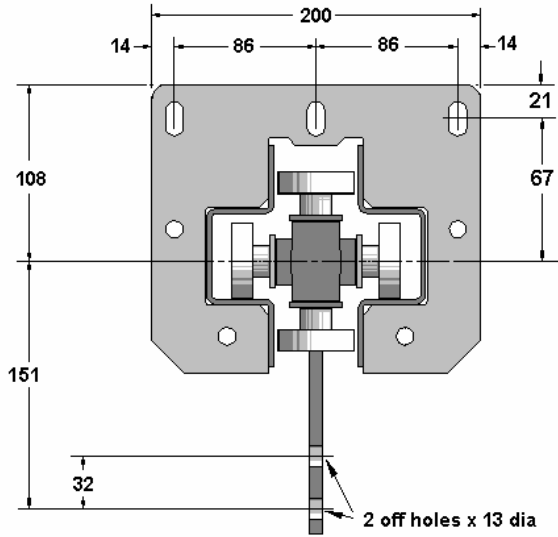

Track

Inspection

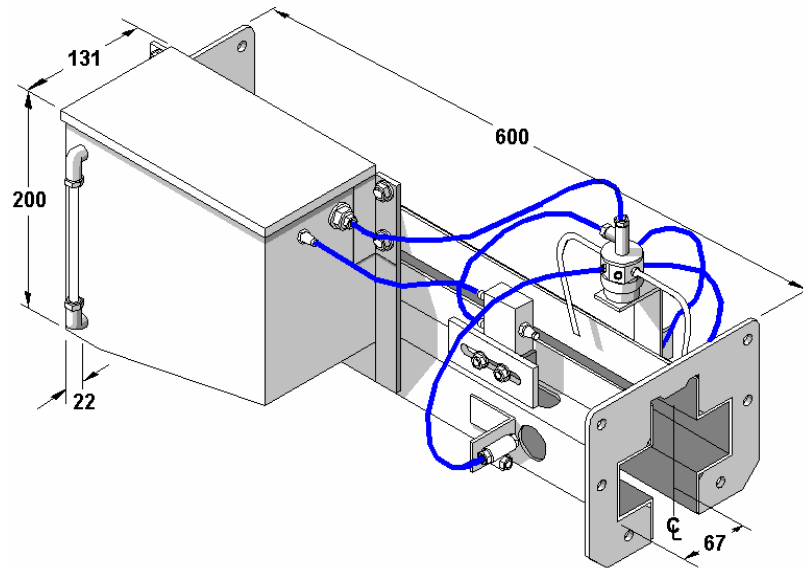
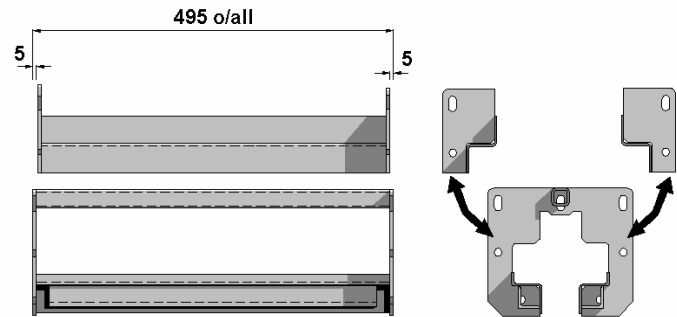

Lubricator

Powertrack 100
Technical Data

